

Full HD Weatherproof Dome Network Camera

Panasonic

K-EF234L Series K-EF234L01E

2 Megapixel 1080p Weatherproof Dome Camera Equipped with IR LED



Specifications

Camera	
Image Sensor	Approx. 1/2.8 type CMOS image sensor
Min Illumination	0.2 lx / F1.4 (color)*, 0 lx / F1.4(IR on) ¹
Gain	Auto/ Manual
Back light compensation	OFF / BLC/ HLC/ WDR
Shutter speed	Auto/ Manual, 1/3 sec~1/100000 sec
Day / Night	Auto(ICR) / Color / Black & White
IR LED Light	Irradiation distance: 30 m
White Balance	Auto/ Sunny / Outdoor / Manual
Digital Noise Reduction	3DNR ON/ OFF
Privacy masking	Up to 4 areas
Video Motion Detection	On/ Off
Lens	
Zoom ratio	4.4x Optical (Motorized zoom/ Motorized focus)
Focal Length	2.7 mm to 12 mm
Angular Field of View	H: 34°(TELE) to 93°(WIDE) V: 18°(TELE) to 50°(WIDE)
Network	
Network	10BASE-T/ 100BASE-TX, RJ45 connector
Resolution	1080P(1920x1080) / 1.3 M (1280x960) / 720P (1280x720) / D1 (704x576/704x480) / CIF (352x288/352x240)
Image compression method	H.264/ H.264H/ H.264B/ MJPEG
Frame Rate	1 to 25/30 fps
Protocol	IPv4/ IPv6, HTTP, HTTPS, SSL, TCP/ IP, UDP, UPnP, ICMP, IGMP, SNMP, RTSP, RTP, SMTP, NTP, DHCP, DNS, PPPoE, DDNS, FTP, QoS, Bonjour, 802.1x, ONVIF compatible
Maximum concurrent access number	20 users (Number of sessions that can connect to cameras at the same time)
Compatible micro SDXC/ SDHC memory card:*2 *3	4 ~ 64 GB
General	
Power source	12 V DC, PoE (IEEE802.3af compliant)
Power Consumption	12 V DC: 710 mA / Approx. 8.5 W PoE 48 V DC: 180 mA / Approx. 8.6 W (Class 0 device)
Ambient Operating Temperature / Humidity	-30 °C to +60 °C {-22 °F to 140 °F} 10 % to 90 % (no condensation)
Water and Dust Resistance	Main body: IP66
Vandal Resistant	Compliant with IK10 (IEC62262)
Dimensions	Φ122 mm × 89 mm (H) {ø4-13/16 inches × 3-1/2 inches (H)}
Weight (approx.)	Approx. 500 g {1.1 lbs}

Key Features

- High-performance CMOS image sensor.
- Vari Focal : 2.7 mm - 12 mm
- H.264 & MJPEG dual-stream encoding
- 30fps@1080P (1920 ×1080) & 30fps@720p (1280 × 720).
- Support ICR for day time and night time operation.
- Max. IR LEDs length 30 m.
- IP66 rated water and dust resistant.
- PoE.

Appearance

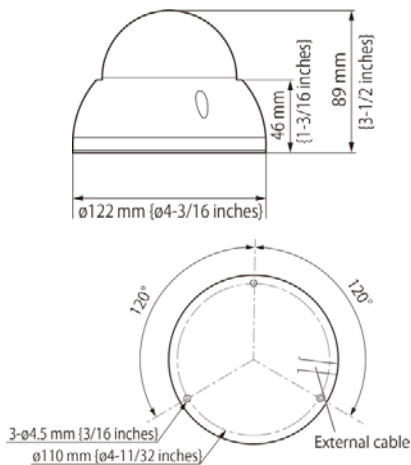

Important

- Safety Precaution: Carefully read the operating instruction manual before using this product.
- Panasonic cannot be responsible for the performance of the network and/or other manufacturers' products used on the network.

*1 [Image Adjust] Shutter: (0-)80 ms, Gain: (0-)50"

*2 When repeatedly recording images on a micro SD memory card using the auto overwrite function, make sure to use a micro SD memory card with high reliability and durability.

*3 Use the micro SD memory card that complies with UHS-1 (Ultra High Speed-1) in the case of SD Speed Class 10.

- All pictures are simulated.
- Weights and dimensions are approximate.
- Specifications are subject to change without notice.

DISTRIBUTED BY: