

Panasonic Chest Chiller is designed for beverage and daily food which is for commercial used as mini-mart, supermarket and restaurant

Single phase  
220-240V  
50Hz

### FEATURES

- Glass-slide door chest chiller
- Inside temperature 0~4°C
- The insulation is made of polyurethane cyclopentane



■ SCR-PR697ST-HK

External Dimension (mm)

W 815 × D 628 × H 835

Capacity (Effective)

133 Liter

#### Technical data

Model	External dimension	Capacity (Effective)	Performance	Weight
SCR-PR697ST-HK	W815x D628x H835(mm)	133L	0~4°C (AT32°C, without direct sunlight)	47kg

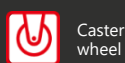
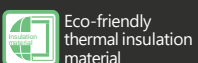

## Specification

Model		SCR-PR697ST-HK
Dimensions (W x D x H) (mm)	External	815 x 628 x 835
	Internal	690 x 480 x 654
Performance		0~4°C (AT32°C, without direct sunlight)
Capacity (Effective)		133L
Material (Exterior)		Bake on Acrylic Finish on Steel Sheet (Color : S-White)
Insulation		Rigid Polyurethane Foam (Cyclopentane)
Door		2- Hard Coated Low E Glasses Panel (Slide Glass)
Refrigeration System	Compressor	Hermatic type
	Refrigerant	R-134a
	Evaporator	Copper Tube Wrapped on Inner Liner
	Temp Control	Mechanical Thermostat with Indicative Lamp
	Condenser	Wire Cond & Tube Natural Convection (at the Back side of Cabinet)
	Defrost	Off system
Power source		220V-240V / 50Hz
Accessories		Key Lock x1
Weight		47kg

## Dimensional drawing (mm)

### SCR-PR697ST-HK

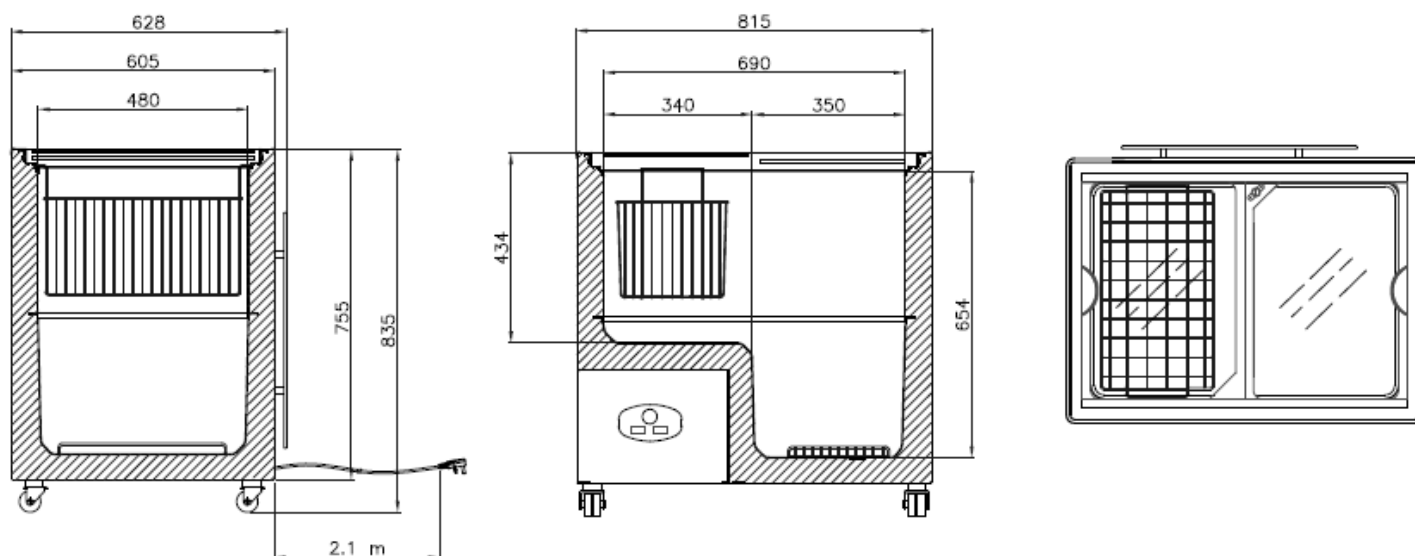

### Safety Precaution

- All of our products in this catalog are designed for commercial use.
  - Please consult the operation & installation manual before use and operate the product correctly.
  - Please consult a Panasonic agent regarding product installation.
  - These products are for indoor use only, do not use them outdoors.
  - Please don't use these products for unintended purposes. Doing so could cause an accident.
  - Please take measures to prevent falls.
  - Do not use the products to store volatile or flammable substances such as benzene or alcohol cylinders. Doing so could cause an explosion.
  - Only use the products for exhibiting food items for sale or for temporary storage.
- Using the products for other purposes could cause a loss in quality of the items stored, among other problems.

※ All pictures are simulated.

※ Design and specification are subject to change without prior notice.

©Panasonic Commercial Equipment Systems Co., Ltd.

**Panasonic Commercial Equipment Systems Asia Pacific**  
202 Bedok South Ave 1, Blk B #01-15, Singapore  
TEL:+65 6338 6411

#### <Reference phone number>

Japan:+81 3 6364 3434

Thailand:+66 2712 2581

Hong Kong:+852 2367 0181

Taiwan:+8862 2598 0599

Philippines:+632 284 2300

Vietnam:+84 8 3813 1001

# Panasonic®

The date of issue :September 2019

1909P-TH-CJ401 ver1