

Panasonic[®]

Operating Instructions

Digital Cordless Phone

Model No. **KX-TGD510HK**
KX-TGD512HK



Model shown is KX-TGD510.

***Before initial use, see “Getting Started”
on page 8.***

Thank you for purchasing a Panasonic product.

Please read these operating instructions before using the unit and save them for future reference.

Table of Contents

Introduction

Model composition	3
Accessory information	3
Graphical symbols for use on equipment and their descriptions	4

Important Information

For your safety	5
Important safety instructions	6
For best performance	6
Other information	6
Specifications	7

Getting Started

Setting up	8
Controls	10
Display icons	10
Turning the power on/off	11
Language setting	11
Date and time	12
Other settings	12

Making/Answering Calls

Making calls	13
Answering calls	13
Useful features during a call	13
Intercom	15
Key lock	15
Power backup operation	16

Nuisance Call Block

Using the call block button	17
Storing unwanted callers	17

Phonebook

Phonebook	19
Speed dial	20

Programming

Menu list	21
Alarm	25
Do not disturb mode	25
Baby monitor	26
Other programming	27
Registering a unit	28

Caller ID Service

Using Caller ID service	30
Caller list	30

Useful Information

Voicemail service	31
Character entry	31
Error messages	33
Troubleshooting	33

Index

Index.....	37
------------	----

Model composition

Series	Model No.	Base unit	Handset	
		Part No.	Part No.	Quantity
KX-TGD510 series	KX-TGD510	KX-TGD510	KX-TGDA50	1
	KX-TGD512	KX-TGD510	KX-TGDA50	2

Accessory information

Supplied accessories

No.	Accessory item/Part number	Quantity	
		KX-TGD510	KX-TGD512
①	AC adaptor for base unit/PNLV226E	1	1
②	Telephone line cord	2	2
③	Rechargeable batteries	2	4
④	Handset cover*1	1	2
⑤	Charger	–	1
⑥	AC adaptor for charger/PNLV233E	–	1

*1 The handset cover comes attached to the handset.

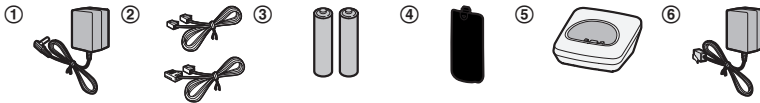













Additional/replacement accessories

Please contact your nearest Panasonic dealer for sales information.
For enquiry, please call hotline 2313 0666.

Accessory item	Model number/Specifications
Rechargeable batteries	Battery type: – Nickel metal hydride (Ni-MH) – 2 x AAA (R03) size for each handset – 1.2 V
DECT repeater	KX-A405, KX-A406

Introduction

Graphical symbols for use on equipment and their descriptions

Symbol	Explanation	Symbol	Explanation
	Alternating current (A.C.)		Class II equipment (equipment in which protection against electric shock relies on Double Insulation or Reinforced Insulation)
	Direct current (D.C.)		"ON" (power)
	Protective earth		"OFF" (power)
	Protective bonding earth		Stand-by (power)
	Functional earth		"ON"/"OFF" (power; push-push)
	For indoor use only		Caution, risk of electric shock

Important Information

For your safety

To prevent severe injury and loss of life/property, read this section carefully before using the product to ensure proper and safe operation of your product.

WARNING

Power connection

- Use only the power source marked on the product.
- Do not overload power outlets and extension cords. This can result in the risk of fire or electric shock.
- Completely insert the AC adaptor/power plug into the power outlet. Failure to do so may cause electric shock and/or excessive heat resulting in a fire.
- Regularly remove any dust, etc. from the AC adaptor/power plug by pulling it from the power outlet, then wiping with a dry cloth. Accumulated dust may cause an insulation defect from moisture, etc. resulting in a fire.
- Unplug the product from power outlets if it emits smoke, an abnormal smell, or makes an unusual noise. These conditions can cause fire or electric shock. Confirm that smoke has stopped emitting and contact an authorised service centre.
- Unplug from power outlets and never touch the inside of the product if its casing has been broken open.
- Never touch the plug with wet hands. Danger of electric shock exists.

Installation

- To prevent the risk of fire or electrical shock, do not expose the product to rain or any type of moisture.
- Do not place or use this product near automatically controlled devices such as automatic doors and fire alarms. Radio waves emitted from this product may cause such devices to malfunction resulting in an accident.

- Do not allow the AC adaptor or telephone line cord to be excessively pulled, bent or placed under heavy objects.

Operating safeguards

- Unplug the product from power outlets before cleaning. Do not use liquid or aerosol cleaners.
- Do not disassemble the product.
- Do not spill liquids (detergents, cleansers, etc.) onto the telephone line cord plug, or allow it to become wet at all. This may cause a fire. If the telephone line cord plug becomes wet, immediately pull it from the telephone wall jack, and do not use.

Medical

- Consult the manufacturer of any personal medical devices, such as pacemakers or hearing aids, to determine if they are adequately shielded from external RF (radio frequency) energy. (The product operates in the frequency range of 1.88 GHz to 1.90 GHz, and the RF transmission power is 250 mW (max.).)
- Do not use the product in health care facilities if any regulations posted in the area instruct you not to do so. Hospitals or health care facilities may be using equipment that could be sensitive to external RF energy.

CAUTION

Installation and location

- Never install telephone wiring during an electrical storm.
- Never install telephone line jacks in wet locations unless the jack is specifically designed for wet locations.
- Never touch uninsulated telephone wires or terminals unless the telephone line has been disconnected at the network interface.
- Use caution when installing or modifying telephone lines.
- The AC adaptor is used as the main disconnect device. Ensure that the AC outlet is installed near the product and is easily accessible.

Important Information

- This product is unable to make calls when:
 - the handset batteries need recharging or have failed.
 - there is a power failure.
 - the key lock feature is turned on.

Battery

- We recommend using the batteries noted on page 3. **USE ONLY rechargeable Ni-MH batteries AAA (R03) size.**
- Do not mix old and new batteries.
- Do not open or mutilate the batteries. Released electrolyte from the batteries is corrosive and may cause burns or injury to the eyes or skin. The electrolyte is toxic and may be harmful if swallowed.
- Exercise care when handling the batteries. Do not allow conductive materials such as rings, bracelets, or keys to touch the batteries, otherwise a short circuit may cause the batteries and/or the conductive material to overheat and cause burns.
- Charge the batteries provided with or identified for use with this product only, in accordance with the instructions and limitations specified in this manual.
- Only use a compatible base unit (or charger) to charge the batteries. Do not tamper with the base unit (or charger). Failure to follow these instructions may cause the batteries to swell or explode.

Important safety instructions

When using your product, basic safety precautions should always be followed to reduce the risk of fire, electric shock, and injury to persons, including the following:

1. Do not use this product near water for example, near a bathtub, washbowl, kitchen sink, or laundry tub, in a wet basement or near a swimming pool.
2. Avoid using a telephone (other than a cordless type) during an electrical storm. There may be a remote risk of electric shock from lightning.
3. Do not use the telephone to report a gas leak in the vicinity of the leak.

4. Use only the power cord and batteries indicated in this manual. Do not dispose of batteries in a fire. They may explode. Check with local codes for possible special disposal instructions.

SAVE THESE INSTRUCTIONS

For best performance

Environment

- The product should be kept free from excessive smoke, dust, high temperature, and vibration.
- When you leave the product unused for a long period of time, unplug the product from the power outlet.
- The product should be kept away from heat sources such as heating devices, cooking appliances, etc. It should not be placed in rooms where the temperature is less than 0 °C or greater than 40 °C. Damp basements should also be avoided.
- Operating the product near electrical appliances may cause interference. Move away from the electrical appliances.

Other information

CAUTION: Risk of explosion if battery is replaced by an incorrect type. Dispose of used batteries according to the instructions.

Notice for product disposal, transfer, or return

- This product can store your private/confidential information. To protect your privacy/confidentiality, we recommend that you erase information such as phonebook or caller list entries from the memory before you dispose of, transfer, or return the product.

Important Information

Information on Disposal in other Countries outside the European Union

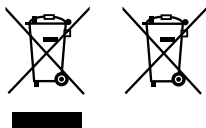

These symbols are only valid in the European Union. If you wish to discard these items, please contact your local authorities or dealer and ask for the correct method of disposal.

Note for the battery removal procedure

Refer to "Removing the battery" on page 9.

Specifications

- **Standard:**
DECT (Digital Enhanced Cordless Telecommunications),
GAP (Generic Access Profile)
- **Number of channels:**
120 Duplex Channels
- **Frequency range:**
1.88 GHz to 1.90 GHz
- **RF transmission power:**
Approx. 10 mW (average power per channel)
250 mW (max.)
- **Power source:**
100–240 V AC, 50/60 Hz
- **Rechargeable battery:**
AAA (R03) Ni-MH battery (1.2 V, 550 mAh)
- **Power consumption:**
Base unit:
Standby: 1.0 W
Maximum: 3.5 W
Charger:
Standby: 0.1 W
Maximum: 1.8 W
- **Operating conditions:**
0 °C–40 °C, 20 %–80 % relative air humidity (dry)
- **Dimensions:**

Base unit: Approx. 87 mm × 126 mm × 101 mm

Handset: Approx. 170 mm × 48 mm × 30 mm

Charger: Approx. 41 mm × 72 mm × 74 mm

● **Mass (weight):**

Base unit: Approx. 130 g

Handset: Approx. 130 g

Charger: Approx. 40 g

Getting Started

Setting up

Connections

■ Base unit

- ① Connect the AC adaptor to the unit by pressing the plug firmly.
- ② Connect the AC adaptor to the power outlet.
- ③ Connect the telephone line cord to the unit, then to the telephone line jack until you hear a click.
- ④ A DSL/ADSL filter (not supplied) is required if you have a DSL/ADSL service.

Note:

- Use only the supplied Panasonic AC adaptor PNLV226E.
- Use only the supplied telephone line cord.

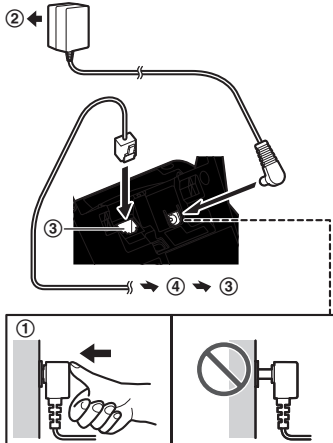

■ Charger

- ① Connect the AC adaptor plug to the unit until you hear a click.

- ② Connect the AC adaptor to the power outlet.

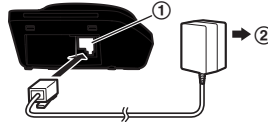

Note:

- Use only the supplied Panasonic AC adaptor PNLV233E.

Battery installation

- USE ONLY rechargeable Ni-MH batteries AAA (R03) size (A).
- Do NOT use alkaline/manganese/Ni-Cd batteries.
- Confirm correct polarities (+, -).

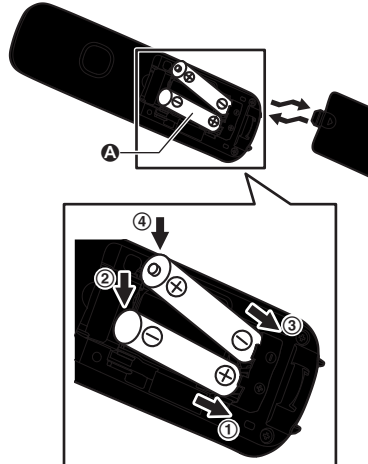

Removing the battery

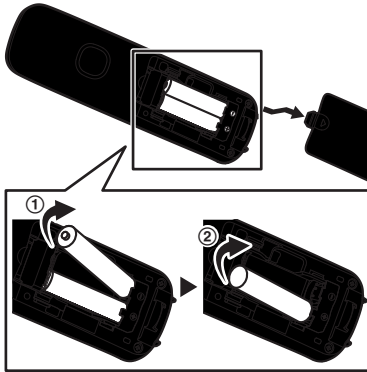

Battery charging

Charge for about 7 hours.

Note for battery charging

- Clean the charge contacts with a soft and dry cloth once a month. Before cleaning the unit, disconnect from power outlets and any telephone line cords.

Battery level

Icon	Battery level
	High
	Medium
	Low
	Needs charging.

Note:

- At the end of each call, the unit displays a large icon for a few moments to indicate the battery level.
- You can set the unit to beep when the battery needs charging (page 12).

Ni-MH battery performance (supplied batteries)

Operation	Operating time
In continuous use	18 hours max.
Not in use (standby)	200 hours max.

Note:

- To maximise battery life, it is recommended that the handset batteries be fully discharged (used) until flashes once every few months.
- Actual battery performance depends on usage and ambient environment.

Getting Started

Controls

Handset

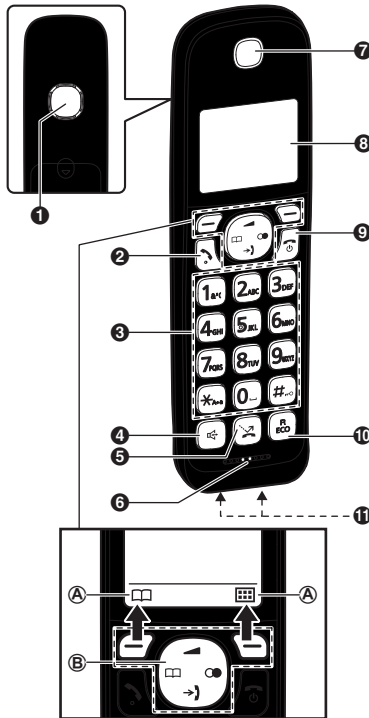

- 1 Speaker
- 2 (Talk)
- 3 Dial keypad
- 4 (Speakerphone)
- 5 (Call block)
- 6 Microphone
- 7 Receiver
- 8 Display
- 9 (Off/Power)
- 10 (R/ECO)
R: Recall/Flash

ECO: Eco mode shortcut key

- 1 Charge contacts
- A Soft keys
- B Navigator key
 - , , , or : Scroll through various lists and items.
 - or (): Adjust the receiver or speaker volume while talking.
 - (Caller list): View the caller list.
 - (Phonebook): View the phonebook entry.
 - (Redial): View the redial list.

Base unit

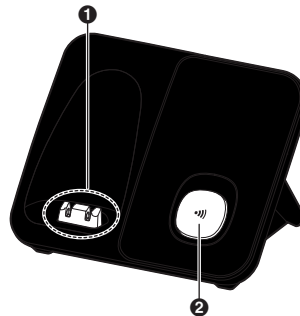

- 1 Charge contacts
- 2 (Locator)

Display icons

Handset display items

Item	Meaning
	Range status: The more bars visible, the closer the handset is to the base unit.
	Out of base unit range
	Security for phone calls is set to "Enhanced". (page 28)
	Paging, intercom mode*1
	Speakerphone is on. (page 13)

Getting Started

Item	Meaning
	The line is in use. <ul style="list-style-type: none"> When flashing slowly: The call is on hold. When flashing rapidly: An incoming call is now being received.
	Missed call*2
	Eco mode is set to "Eco". (page 12)
	Noise reduction is set. (page 14)
	The LCD and key backlight is off. (page 23)
	Battery level
	Alarm is on. (page 25)
	Privacy mode is on.*1 (page 23)
	Ringer volume is off. (page 22)
	Do not disturb mode is on. (page 25)
	Nuisance call blocked.*2 (page 17)
	New voicemail message received.*3 (page 31)
	Baby monitor is activated. The name/number displayed next to the icon indicates the monitoring unit. (page 26)
Line in use	Someone is using the line.*1

*1 KX-TGD512

*2 Caller ID subscribers only

*3 Voicemail subscribers only

Handset soft key icons

Icon	Action
	Returns to the previous screen or outside call.
	Displays the menu.
OK	Accepts the current selection.
	Makes a call. (page 20)

Icon	Action
	Temporarily turns off the ringer for incoming calls. (page 13)
	Places a call on hold.*1
	Opens the phonebook.
	Allows you to edit phone numbers. (page 18)
	Adds new entry. (page 20, 26)
	Turns the key lock feature off. (page 15)
	Stops alarm.
	Snooze button on the alarm. (page 25)
	Selects entries or handset. (page 25)
	Stores phone numbers. (page 13, 19)
	Erases the selected item.
	Allows you to make an intercom call.*1
C	Erases a number/character.
	Puts the call on mute.

*1 KX-TGD512

Turning the power on/off

Press [] for about 2 seconds.

Language setting

Display language

- #1110
- : Select your desired language. → **[OK]** → []

Getting Started

Date and time

- 1 **[☰]#101**
- 2 Enter the current date, month, and year.
→ **[OK]**
Example: 12 July, 2019
1 2 0 7 1 9
- 3 Enter the current hour and minute.
Example: 9:30
0 9 3 0
 - You can select 24-hour or 12-hour clock format (“**AM**” or “**PM**”) by pressing **[☒]**.
- 4 **[OK]** → **[📞]**

Other settings

Eco mode setting

You can select the desired eco mode setting by pressing **[R/ECO]**.

The following settings are available for eco mode.

- “**Eco**”: Reduces the base unit transmission power by up to 90 % in standby mode. When this setting is selected, **ECO** is displayed on the handset display instead of **Y**.
- “**Eco Off**” (default setting): Turns off eco mode. When this setting is selected, **ECO** are not displayed in the handset display.

Note:

- When there is another cordless phone in use nearby, the base unit transmission power may not be reduced. (KX-TGD512)
- When eco mode is active, the range of the base unit is reduced in standby mode.
- If you set repeater mode to “on” (page 29):
 - Eco mode is disabled.
 - “**Eco Mode**” is not displayed in the display menu (page 22).

Dialling mode

- 1 **[☰]#120**
- 2 **[↕]**: Select the desired setting. → **[OK]**
→ **[📞]**

Low battery alert

This feature allows the unit to beep when the battery needs charging.

When this feature is turned on, the unit notifies you as follows.

■ When the handset is in standby mode:

- If the battery needs charging, the unit beeps at the selected interval up to 3 times.

Note for handset:

- At the end of each call, the unit displays a large icon for a few moments to indicate the battery level.

Setting low battery alert

- 1 **[☰]#176**
- 2 **[↕]**: Select the desired setting. → **[OK]**
→ **[📞]**

Making/Answering Calls

Making calls

- 1 Lift the handset and dial the phone number.
 - To correct a digit, press [C].
- 2 [] or []
 - To adjust the receiver or speaker volume, press [▲] or [▼] repeatedly.
- 3 When you finish talking, press [].

Note:

- To switch to the speaker, press []. To switch back to the receiver, press []/[].
- In step 1, you can store the dialled phone number to the phonebook by pressing [].

Making a call using the redial list

The last 10 phone numbers dialled are stored in the redial list.

- 1 []
- 2 []: Select the desired entry. → []

Pause (for PBX/long distance service users)

A pause is sometimes required when making calls using a PBX or long distance service. When storing a calling card access number and/or PIN in the phonebook, a pause is also needed (page 20).

Example: If you need to dial the line access number "0" when making outside calls with a PBX:

- 1 [] → [0] → [▲] (Pause)
- 2 Dial the phone number. → []

Answering calls

- 1 Lift the handset and press [] or [] when the unit rings.
- 2 When you finish talking, press [].

Auto talk: You can answer calls simply by lifting the handset (page 23).

Temporary handset ringer off: Press [].

Adjusting the ringer volume

Press [▲] or [▼] repeatedly while ringing.

- To turn the ringer off, press [▼] repeatedly.

Useful features during a call

Hold

- 1 Press [] during an outside call.
- 2 []: "Hold" → [OK]
- 3 To release hold, press [].
 - Another handset user can take the call by pressing [].

Note:

- After holding for 10 minutes, the call is disconnected.

Mute

- 1 Press [] during a call.
- 2 To return to the call, press [].

Recall/flash

[R/ECO] allows you to use the special features of your host PBX.

Note:

- To change the recall/flash time, see page 23.

For call waiting or Call Waiting Caller ID service users

To use call waiting or Call Waiting Caller ID, you must first subscribe with your phone service provider.

This feature allows you to receive calls while you are already talking on the phone. If you receive a call while on the phone, you will hear a call waiting tone.

Making/Answering Calls

If you subscribe to both **Caller ID and Call Waiting with Caller ID services**, the 2nd caller's information is displayed on the unit that is in use after you hear the call waiting tone.

- 1 Press **[R/ECO]** to answer the 2nd call.
- 2 To switch between calls, press **[R/ECO]**.

Note:

- Please contact your phone service provider for details and availability of this service in your area.

Temporary tone dialling (for rotary/pulse service users)

Press **[X]** before entering access numbers which require tone dialling.

Handset noise reduction

This feature allows you to hear the voice of the person you are talking to more clearly, by reducing the surrounding noise coming from the other party's telephone.

- 1 Press **[M]** while talking.
- 2 **[↕]**: "Noise Reduction On" or "Noise Reduction Off" → **[OK]**

Note:

- Depending on the environment where this handset is being used, this feature may not be effective.
- This feature is not available while using the speakerphone.

Handset equalizer

This feature clarifies the voice of the person you are talking to, producing a more natural-sounding voice that is easier to hear and understand.

- 1 Press **[M]** while talking.
- 2 **[↕]**: "Equalizer" → **[OK]**
- 3 **[↕]**: Select the desired setting.
- 4 Press **[OK]** to exit.

Note:

- Depending on the condition and quality of your telephone line, this feature may emphasise existing line noise. If it becomes difficult to hear, select another setting.
- This feature is not available while using the speakerphone.

Call share

Available for:
KX-TGD512

While you are on an outside call, another unit can join the conversation. Only 2 units can join an outside call.

Note:

- To prevent other users from joining your conversations, turn the privacy mode on (page 23).

Transferring calls, conference calls

Available for:
KX-TGD512

- 1 During an outside call, press **[M]**.
- 2 **[↕]**: "Intercom" → **[OK]**
- 3 **[↕]**: Select the desired unit. → **[OK]**
 - If you select "Voice Paging", the call will be switched from the ear-receiver mode to the speakerphone mode.
- 4 Wait for the paged party to answer.
 - If the paged party does not answer, press **[S]** to return to the outside call.
- 5 **To complete the transfer:**
Press **[P]**.
To establish a conference call:
[M] → **[↕]**: "Conference" → **[OK]**
 - To leave the conference, press **[P]**.
 - To put the outside call on hold: **[M]** → **[↕]**: "Hold" → **[OK]**
To resume the conference: **[M]** → **[↕]**: "Conference" → **[OK]**

- To cancel the conference: [END] → [UP]: "Stop Conference" → [OK]

Intercom

Available for:
KX-TGD512

Making an intercom call

- 1 [END] → [UP]: "Intercom" → [OK]
- 2 [UP]: Select the desired unit or "Voice Paging". → [OK]
 - If you select "Voice Paging", speak into the microphone after the beep. Your voice will be heard using the speakers of all handsets, until a paged party answers your page or until you press [OFF].
After the other party answers, the speakerphone mode is turned on.

Note:

- You cannot use voice paging if other units are in use.

Turning auto intercom on/off

This feature allows the handset to answer intercom calls automatically without pressing [OFF] when it is called.

- 1 [END] [F] [2] [7] [3]
- 2 [UP]: Select the desired setting. → [OK] → [OFF]

Note:

- This feature is not available for all handsets paging and voice paging even if it is turned on.

Key lock

The handset can be locked so that no calls or settings can be made. Incoming calls can be answered, but most other functions are disabled while the key lock is on.

Important:

- Calls to emergency numbers cannot be made until key lock is turned off.

Setting the key lock mode

- 1 [END] [F] [2] [4] [6]
- 2 [UP]: Select the desired setting. → [OK] → [OFF]

Turning the key lock on/off

■ Without a password:

- To turn the key lock on**
Press [F] for about 2 seconds during standby mode.
- To turn the key lock off**
Press [OFF] for about 2 seconds.

■ With a password:

- To turn the key lock on**
 - 1 Press [F] for about 2 seconds during standby mode.
 - 2 Enter your key lock password. → [OK] 2 times
- To turn the key lock off**
 - 1 Press [OFF] for about 2 seconds during standby mode.
 - 2 Enter your key lock password. → [OK] 2 times

Note:

- You can turn off the handset while the key lock is on. Depending on the settings, the state of the handset may change when you turn on the handset again:
 - Without a password: The key lock turns off.
 - With a password: The key lock stays on.
- The following keys and operations are available when the key lock is on:
 - [OFF] to stop the alarm.
 - Without a password: During a call, all available features can be used as usual. When the call ends, the handset turns the key lock on again.
- When the key lock mode is set to "with Password":
 - Dial keypad and [OFF] cannot be used during a call.



Making/Answering Calls

- [↵] (right soft key) is not available during chain dial (page 19).

Power backup operation

When a power failure occurs, the charged handset temporarily supplies power to the base unit (power backup mode). This allows you to make and receive calls using a handset during a power failure. The base unit will not perform any other functions (page 24).

Important:

- If a handset is not placed on the base unit when a power failure occurs, "Base no power Press [⏻]" is displayed. After pressing [⏻] on the handset, place it on the base unit to start power backup mode.
- Power backup mode will not work if the battery level of the power supplying handset is  .
- Do not lift the power supplying handset from the base unit during power backup mode.

Ni-MH battery performance (supplied batteries) during power backup mode

When the batteries are fully charged, operating time of the handset in power backup mode varies depending on usage.

- Continuous use of the handset in power backup mode: 2 hours max.
- Continuous use of the handset other than a handset in power backup mode: 3 hours max.
- Not in use in power backup mode: 3 hours max.

Making calls during a power failure

- **When only 1 handset is registered:**
 - 1 Lift the handset and dial the phone number.

- 2 Within 1 minute, place the handset on the base unit.
 - Wait until speakerphone is turned on automatically and the call is made.
- 3 When the other party answers the call, keep the handset on the base unit and talk using the speakerphone.
- 4 When you finish talking, press [⏻].

- **When 2 or more handsets are registered:** You should leave one handset on the base unit for supplying power, and use another handset for making calls.

Note:

- The range of the base unit is limited during a power failure. Please use the handset close to the base unit.

Answering calls during a power failure

- **When only 1 handset is registered:**
 - 1 When the unit rings, keep the handset on the base unit and press [↵] or [⏻].
 - Speakerphone is turned on.
 - 2 When you finish talking, press [⏻].
- **When 2 or more handsets are registered:** When the unit rings, use a handset which is not supplying power to the base unit.
 - Do not use or lift the handset which is placed on the base unit during power backup mode.

Note:

- The range of the base unit is limited during a power failure. Please use the handset close to the base unit.

Using the call block button

You can press [] in the following situations to disconnect the current call and add a phone number to the call block list:

- when an incoming call is being received
- when talking on an outside call

Once a phone number has been added to the call block list, the unit will block calls from that phone number in the future.

- 1 Press [] under the situations shown above.
- 2 Confirm the call block number and press [OK].
 - The call block number is stored in the call block list, "Caller Blocked" is displayed, and then the call is disconnected.

Note:

- If the call has no phone number, the call is blocked but it is not stored in the call block list.
- The call block feature is not available for intercom calls or calls received by call waiting.
- Blocked calls are logged in the caller list.

Storing unwanted callers

The unit can block calls by storing the desired items in the call block list beforehand (Caller ID subscribers only).

- "Single Number": The unit blocks calls from specific phone numbers stored in the call block list.
- "Range of Numbers": The unit blocks calls that begin with a number stored in the call block list, such as a toll-free phone number prefix or certain area codes.
- "Withheld": The unit blocks calls that have no phone number.

Single phone numbers and ranges of numbers can be stored in the call block list up to 250 items in total.

Blocking unwanted callers:

When a call is received, the unit does not ring while the caller is being identified.

If the caller's phone number matches an entry in the call block list, the unit emits no sound to the caller, and disconnects the call.

Storing a single phone number

Important:

- You must include the area code when storing phone numbers in the call block list.

Adding call blocked numbers from the caller list

- 1 []
- 2 []: Select the desired entry to be blocked.
- 3 [] → []: "Yes" → [OK] → []

Adding call blocked numbers manually

- 1 []
- 2 []: "Single Number" → [OK]
- 3 [] → []: "Add" → [OK]
- 4 Enter the phone number (24 digits max.). → [OK] → []

Storing a range of number

- 1 []
- 2 []: "Range of Numbers" → [OK]
- 3 [] → []: "Add" → [OK]
- 4 Enter the desired number (2-8 digits). → [OK] → []

Blocking incoming calls that have no phone number

You can block calls when no phone number is provided, such as private callers.

- 1 []
- 2 []: "Withheld" → [OK]

Nuisance Call Block

- 3 [↕]: Select the desired setting. → [OK]
→ [⏪]

Viewing/editing/erasing call block numbers

- 1 [↔]
- 2 [↕]: "Single Number" or "Range of
Numbers" → [OK]
- 3 [↕]: Select the desired entry.
- 4 To edit a number:
[☒] → Edit the number. → [OK] →
[⏪]
To erase a number:
[X] → [↕]: "Yes" → [OK] → [⏪]

Phonebook

You can add 150 names (16 characters max.) and phone numbers (24 digits max.) to the phonebook.

Adding phonebook entries

- 1 [OK] → [RECALL]
- 2 [↕]: "New Entry" → [OK]
- 3 Enter the party's name. → [OK]
 - You can change the character entry mode by pressing [RECO] (page 31).
- 4 Enter the party's phone number. → [OK]
- 5 [↕]: Select the desired category. → [OK] 2 times → [PHONE]

Storing a redial list number to the phonebook

- 1 [CALL]
- 2 [↕]: Select the desired entry. → [RECALL]
- 3 To store the name, continue from step 3, "Editing entries", page 19.

Storing caller information to the phonebook

- 1 [→]
- 2 [↕]: Select the desired entry. → [RECALL]
- 3 [↕]: "Save Phonebook" → [OK]
- 4 To store the name, continue from step 3, "Editing entries", page 19.

Categories

You can assign your phonebook entries to categories for each searching. You can assign a ringtone to each category to help identify incoming calls (Caller ID required).

Changing category names/setting category ringer tone

- 1 [RECALL] → [RECALL]
- 2 [↕]: "Category" → [OK]
- 3 [↕]: Select the desired category. → [OK]
- 4 **To change category names**
 [↕]: "Category Name" → [OK] → Edit the name. → [OK]
To set category ringer tone
 [↕]: Select the current setting of the category ringer tone. → [OK] → [↕]: Select the desired ringer tone. → [OK]
- 5 [PHONE]

Finding and calling from a phonebook entry

- 1 [RECALL]
- 2 [↕]: Select the desired entry.
- 3 [PHONE]

Editing entries

- 1 Find the desired entry (page 19). → [RECALL]
- 2 [↕]: "Edit" → [OK]
- 3 Edit the name if necessary. → [OK]
- 4 Edit the phone number if necessary. → [OK]
- 5 [↕]: Select the desired category (page 19). → [OK] 2 times → [PHONE]

Erasing an entry

- 1 Find the desired entry (page 19).
- 2 [RECALL] → [↕]: "Erase" → [OK]
- 3 [↕]: "Yes" → [OK] → [PHONE]

Chain dial

This feature allows you to dial phone numbers in the phonebook while you are on a call. This feature can be used, for example, to dial a calling card access number or bank account

Phonebook

PIN that you have stored in the phonebook, without having to dial manually.

- 1 During an outside call, press [□].
- 2 [↕]: Select the desired entry.
- 3 Press [↵] (right soft key) to dial the number.

Note:

- When storing a calling card access number and your PIN in the phonebook as one phonebook entry, press [Δ] (Pause) to add pauses after the number and PIN as necessary (page 13).
- If you have rotary/pulse service, you need to press [☒] before pressing [□] in step 1 to change the dialling mode temporarily to tone. When adding entries to the phonebook, we recommend adding [☒] to the beginning of phone numbers you wish to chain dial (page 19).

Speed dial

You can assign 1 phone number to each of the dial keys ([1] to [9]) on the handset.

Adding phone numbers to speed dial keys

■ By entering phone numbers:

- 1 Press and hold the desired speed dial key ([1] to [9]). → [□↵]
- 2 [↕]: “Manual” → [OK]
- 3 Enter the party's name. → [OK]
- 4 Enter the party's phone number. → [OK] 2 times → [☎]

■ From the phonebook:

- 1 Press and hold the desired speed dial key ([1] to [9]). → [□↵]
- 2 [↕]: “Phonebook” → [OK]
- 3 [↕]: Select the desired entry. → [OK] → [☎]

Note:

- If you edit a phonebook entry which is assigned to a speed dial key, the edited

entry does not transfer to the speed dial key.

Editing an entry

- 1 Press and hold the desired speed dial key ([1] to [9]). → [☐]
- 2 [↕]: “Edit” → [OK]
- 3 Edit the name if necessary. → [OK]
- 4 Edit the phone number if necessary. → [OK] 2 times → [☎]

Erasing an entry

- 1 Press and hold the desired speed dial key ([1] to [9]). → [☐]
- 2 [↕]: “Erase” → [OK]
- 3 [↕]: “Yes” → [OK] → [☎]

Making a call

Press and hold the desired speed dial key ([1] to [9]). → [☎]

Menu list

Scrolling through the display menus: [F5] → Press [▼] or [▲] to select the desired main menu. → [OK]

OR

Using the direct command code: [F5] → Enter the desired code.

Example: Press [F5]#1101.

- To exit the operation, press [F6].

Display the menu tree and direct command code table

Main menu: ☎ “Time Settings”

Sub-menu 1	Sub-menu 2	Settings <Default>	Code	Page
Set Date/Time	–	–	#101	12
Memo Alarm	Alarm 1-3	<Off> Once Daily Weekly	#720	25
Time Adjustment*1	–	Caller ID <Manual>	#226	–

Main menu: →) “Caller List”

Operation	Code	Page
Viewing the caller list.	#213	30

Main menu: ⚡) “Intercom”*2

Operation	Code	Page
Paging the desired unit.	#274	–

Programming

Main menu:  "Initial Setup"

Sub-menu 1	Sub-menu 2	Settings <Default>	Code	Page
Ringer Setup	Ringer Volume	Off-6 <6>	#160	-
	Ringtone* ³	<Ringtone 1>	#161	-
	Do Not Disturb Mode - On/Off	On <Off>	#238	25
	Do Not Disturb Mode - Start/End	<23:00/06:00>	#237	25
	Do Not Disturb Mode - Ring Delay	30 sec. <60 sec.> 90 sec. 120 sec. No Ringing	#239	25
	Do Not Disturb Mode - Select Category	Category 1-9	#241	26
	First Ring* ⁴	<On> Off	#173	-
Time Settings	Set Date/Time	-	#101	12
	Memo Alarm - Alarm 1-3	<Off> Once Daily Weekly	#720	25
	Time Adjustment* ¹	Caller ID <Manual>	#226	-
Talking Caller ID	-	On <Off>	#162	30
Low Battery Alert	-	Off <Every Hour> Every 3 Hours Every 6 Hours	#176	12
Nuisance Call Block	Single Number	-	#217	17
	Range of Numbers	-		17
	Withheld	On <Off>	#240	17
Speed Dial	-	-	#261	20
Eco Mode* ⁵	-	<Off> Eco	#725	12
Security* ⁵	-	<Normal> Enhanced	#729	28

Programming

Sub-menu 1	Sub-menu 2	Settings <Default>	Code	Page
Display Setup	LCD & Key Backlight	<On> Off	#276	-
	Contrast (Display contrast)	Level 1-4 <2>	#145	-
	Handset Name	-	#104	27
	Display Name	On <Off>	#105	27
Auto Intercom ²	-	On <Off>	#273	-
Keytones	-	<On> Off	#165	-
Key Lock Mode	-	with Password <without Password>	#246	15
Call Restrict	-	-	#256	28
Auto Talk	-	On <Off>	#200	13
Line Setup	Dial Mode	<Tone> Pulse	#120	12
	Recall/Flash	80 msec. 90 msec. 100 msec. 110 msec. 160 msec. 200 msec. 250 msec. 300 msec. <400 msec.> 600 msec. 700 msec. 900 msec.	#121	13
Privacy Mode ⁶	-	On <Off>	#194	-
Base Unit PIN	-	<0000>	#132	28
Repeater Mode	-	On <Off>	#138	29
Register	Register Handset	-	#130	28
	Cancel Register ⁷	-	#131	29
Select Base	-	<Auto>	#137	29
Cancel Base ⁷	-	-	#139	29

Programming

Sub-menu 1	Sub-menu 2	Settings <Default>	Code	Page
Power Failure	–	<Auto> Off	#152	16
Language	Display	<中文>	#110	11

Main menu: 😊 “Baby Monitor”

Sub-menu 1	Sub-menu 2	Settings <Default>	Code	Page
On/Off	–	On <Off>	#268	26
Sensitivity Level	–	Low <Middle> High	#269	27

Main menu: 🎵 “Ringer Setup”

Sub-menu 1	Sub-menu 2	Settings <Default>	Code	Page
Ringer Volume	–	Off-6 <6>	#160	–
Ringtone ^{*3}	–	<Ringtone 1>	#161	–
Do Not Disturb Mode	On/Off	On <Off>	#238	25
	Start/End	<23:00/06:00>	#237	25
	Ring Delay	30 sec. <60 sec.> 90 sec. 120 sec. No Ringing	#239	25
	Select Category	Category 1-9	#241	26
First Ring ^{*4}	–	<On> Off	#173	–

*1 This feature allows the unit to automatically adjust the date and time each time caller information including date and time is received.
To turn this feature on, select “Caller ID”. To turn this feature off, select “Manual”.
(Caller ID subscribers only)
To use this feature, set the date and time first (page 12).

*2 KX-TGD512

*3 The preset melodies in this product (“Ringtone 3” - “Ringtone 40”) are used with permission of © 2012 - 2017 Copyrights Vision Inc.

*4 If you do not want the unit to ring before the caller information is received, set to “Off”.
(Caller ID subscribers only)

You can only remove the first ring if the unit rings 2 times or more by default, which depends on your phone service provider.

*5 This menu is not displayed when repeater mode is set to “On”.

*6 To prevent other users from joining your conversations with outside callers, turn this feature on.

*7 This menu is not displayed when scrolling through the display menus. It is only available in direct command code.

Alarm

An alarm sounds at the set time for 1 minute and is repeated 5 times at 5 minute intervals (snooze function). A text memo can also be displayed for the alarm. A total of 3 separate alarm times can be programmed for each handset. You can set one of 3 different alarm options (once, daily, or weekly) for each alarm time.

- 1 **[☰]#720**
- 2 **[↕]**: Select the desired alarm. → **[OK]**
- 3 **[↕]**: Select the desired alarm option. → **[OK]**
- 4 Proceed with the operation according to your selection in step 3.
 - **Once:**
Enter the desired date and month. → **[OK]**
 - **Weekly:**
[↕]: Select the desired day of the week and press **[✓]**. → **[OK]**
- 5 Set the desired time. → **[OK]**
- 6 Enter a text memo (10 characters max.). → **[OK]**
- 7 **[↕]**: Select the desired alarm tone. → **[OK]**
- 8 **[↕]**: Select the desired snooze setting. → **[OK]**
- 9 **[OK]** → **[🔔]**

Note:

- Press any dial key or **[🔔]** to stop the sound but keep the snooze function activated.
- If you want to make an outside call when the snooze function is activated, please stop the snooze function before making the call.

Do not disturb mode

Do not disturb mode allows you to select a period of time during which the handset will not ring for outside calls. This feature is useful for time periods when you do not want to be disturbed, for example, while sleeping. Do not disturb mode can be set for each unit. Using the phonebook's category feature (page 19), you can also select categories of callers whose calls override do not disturb mode and ring the handset (Caller ID subscribers only).

Important:

- If you have set the alarm, the alarm sounds even if do not disturb mode is turned on.

Turning do not disturb mode on/off

- 1 **[☰]#238**
- 2 **[↕]**: Select the desired setting. → **[OK]**
- 3 Follow the directions on the display to complete the operation.

Changing the start and end time

- 1 **[☰]#237**
- 2 Follow the directions on the display to complete the operation.

Setting the ring delay

This setting allows the handset to ring during do not disturb mode if the caller waits long enough. After the selected amount of time passes, the handset rings. If you select "No Ringing", the handset never rings during do not disturb mode.

- 1 **[☰]#239**
- 2 **[↕]**: Select the desired setting. → **[OK]**
→ **[🔔]**

Programming

Selecting categories to bypass do not disturb mode

- 1 [M] [#] [2] [4] [1]
- 2 [↕]: Select the desired categories. → [✓]
 - “✓” is displayed next to the selected category numbers.
 - To cancel the selected category: [↕]: Select the category. → Press [✓] again. “✓” disappears.
- 3 [OK] → [↻]

Baby monitor

This feature allows you to listen in on a room where another handset is located, allowing you to easily monitor from different areas of the house or place. The monitored handset (placed in a baby’s room, for example) will automatically call the monitoring handset or the phone number stored when it detects sound.

Important:

- Before using this feature, we recommend that you test this feature and adjust the baby monitor sensitivity as needed, especially if you plan to monitor from outside.
- This feature should not be used as a substitute for a medical or caregiver’s supervision. It is the caregiver’s responsibility to stay close enough to handle any eventuality.

Note:

- During the monitoring mode, battery consumption is faster than usual. We recommend leaving the monitored handset on the base unit.
- The monitored handset never rings while it is being monitored.

Setting the baby monitor

Perform the setting operation with the handset to be monitored (for example, the handset placed in a baby’s room).

To monitor with a handset

The internal baby monitor feature is available between handsets in the same radio cell.

- 1 [M] [#] [2] [6] [8]
- 2 [↕]: “On” → [OK]
- 3 [↕]: Select the desired handset number to monitor with. → [OK]
 - “Baby Monitor” will be displayed.
 - The registered handset name/number is displayed.

Note:

- When this feature is on, another handset can hear the monitored handset by making an intercom call.

To monitor from an outside line

If you enable this feature, the unit will call a pre-programmed phone number when the handset detects sound. After you answer the call, you can listen in on the room where the handset is located.

■ From the phonebook:

- 1 [M] [#] [2] [6] [8]
- 2 [↕]: “On” → [OK]
- 3 [↕]: Select “External” to monitor from an outside line. → [↵]
- 4 [↕]: “Phonebook” → [OK]
- 5 [↕]: Select the phonebook entry. → [OK]
 - “Baby Monitor” will be displayed.

Note:

- If you edit a phonebook entry which is assigned for monitoring, the edited entry does not transfer to the monitor.

■ By entering phone numbers:

- 1 [M] [#] [2] [6] [8]
- 2 [↕]: “On” → [OK]
- 3 [↕]: Select “External” to monitor from an outside line. → [↵]
- 4 [↕]: “Manual” → [OK]
- 5 Enter the desired name. → [OK]

Programming

- 6 Enter the desired number. → [OK] 2 times
 - “Baby Monitor” will be displayed.

Note:

- The registered name/number is displayed.

Turning off the baby monitor

The monitored handset cannot be used while baby monitor is set to “on”.

- 1 Press [M] on the handset being monitored.
- 2 [↕]: “On/Off” → [OK]
- 3 [↕]: “Off” → [OK] → [📞]

Editing an outside monitoring number

- 1 Press [M] on the handset being monitored.
- 2 [↕]: “On/Off” → [OK]
- 3 [↕]: “On” → [OK]
- 4 [↕]: Select the outside line.
- 5 [M] → [↕]: “Edit” → [OK]
- 6 Edit the name if necessary. → [OK]
- 7 Edit the phone number if necessary. → [OK] 2 times

Erasing an outside monitoring number

- 1 Press [M] on the handset being monitored.
- 2 [↕]: “On/Off” → [OK]
- 3 [↕]: “On” → [OK]
- 4 [↕]: Select the outside line.
- 5 [M] → [↕]: “Erase” → [OK]
- 6 [↕]: “Yes” → [OK] → [📞]

Baby monitor sensitivity

You can adjust the sensitivity of the baby monitor. Increase or decrease the sensitivity to adjust the sound level needed to trigger the baby monitor feature.

- This feature cannot be set during a monitoring call.

- 1 Press [M] on the handset being monitored.
- 2 [↕]: “Sensitivity Level” → [OK]
- 3 [↕]: Select the desired setting. → [OK] → [📞]

Answering the baby monitor

■ When monitoring with a handset:

Press [📞] to answer a call.

If you want to respond from the monitoring handset, press [✖].

- The monitoring handset will answer calls automatically when the auto intercom feature is set to “on” (page 15).

Note:

- If you receive an outside call when communicating with the monitored handset, the interrupt tone sounds.

To answer the call, press [📞], then press [📞].

■ When monitoring from an outside line:

Answer the call.

If you want to respond from your monitoring phone, press [7] [1] using tone dialling.

You can turn off the baby monitor feature by pressing [#] [0].

Note:

- The unit disconnects the call automatically after 2 minutes.

Other programming

Changing the handset name

- 1 [M] [#] [1] [0] [4]
- 2 Enter the desired name. → [OK] → [📞]

Displaying the handset name

- 1 [M] [#] [1] [0] [5]

Programming

- 2 [↕]: Select the desired setting. → [OK]
→ [🔒]

Call restriction

You can restrict selected handsets from dialling certain numbers. You can assign up to 6 phone numbers to be restricted, and select which handsets are to be restricted. Storing area codes here prevents the handset from dialling any phone number in that area code.

- 1 [☎]#256
- 2 Enter the base unit PIN (default: "0000").
 - If you forget your PIN, contact an authorised service centre.
- 3 [↕]: Select the handsets to be restricted. → [✓]
 - To cancel the selected handset, press [✓] again. "✓" disappears.
- 4 [OK]
- 5 [↕]: Select a memory location. → [OK]
- 6 Enter the phone number or area code to be restricted (8 digits max.). → [OK] → [🔒]

Enhancing security for phone calls

You can increase the security of phone conversations by setting this feature to "Enhanced". When "Enhanced" is selected,  is displayed. The default setting is "Normal".

- 1 [☎]#729
- 2 [↕]: Selected the desired setting. → [OK]
- 3 [🔒]

Note:

- If you set repeater mode to "on" (page 29):
 - Security is set to "Normal" and  is displayed.
 - "Security" is not displayed in the display menu (page 22).
- When enhanced security is enabled, sound may cut in and out during conversations.

Changing the base unit PIN

Important:

- If you change the PIN (Personal Identification Number), please make note of your new PIN. The unit will not reveal the PIN to you. If you forget your PIN, contact an authorised service centre.

- 1 [☎]#132
- 2 Enter the current 4-digit base unit PIN (default: "0000").
- 3 Enter the new 4-digit base unit PIN. → [OK]
- 4 [↕]: "yes" → [OK] → [🔒]

Registering a unit

Operating additional units

Additional base units

Handsets can be registered to up to 4 base units, allowing you to add additional base units and extend the area in which your handset(s) can be used. If the handset moves out of range of its base unit when "Auto" is selected on base unit (page 29), it looks for another base unit to make or receive calls. A base unit and the handsets it communicates with is called a "radio cell".

Note:

- Calls are disconnected when the handset moves from one radio cell to another.

Registering a handset to a base unit

If for some reason the handset is not registered to the base unit, re-register the handset.

- 1 **Handset:**
[☎]#130
- 2 [↕]: Select a base unit number. → [OK]
 - This number is used by the handset as a reference only.
- 3 **Base unit:**
Press and hold [🔒] for about 5 seconds.

4 Handset:

[OK] → Wait until “Base PIN” is displayed. → Enter the base unit PIN (default: “0000”). → [OK]

- If you forget your PIN, contact an authorised service centre.

Selecting a base unit

When “Auto” is selected, the handset automatically uses any available base unit it is registered to. When a specific base unit is selected, the handset makes and receives calls using that base unit only.

1 [☰] [#] 1 3 7

2 [↕]: Select the desired base unit number, or “Auto”. → [OK]

Important:

- When viewing the phonebook, caller list, etc., only the entries that are stored in the base unit that the handset is currently connected to are displayed.

Deregistering a handset

1 [☰] [#] 1 3 1

- All handsets registered to the base unit are displayed.

2 [↕]: Select the handset you want to cancel. → [OK]

3 [↕]: “Yes” → [OK] → [☎]

Cancelling a base unit

1 [☰] [#] 1 3 9

2 [↕]: Select the base unit you want to cancel. → [OK]

3 [↕]: “Yes” → [OK] → [☎]

Increasing the range of the base unit

You can increase the signal range of the base unit by using a DECT repeater. Please use only the Panasonic DECT repeater noted on page 3. Contact your Panasonic dealer for details.

Important:

- Before registering the repeater to this base unit, you must turn the repeater mode on.
- If you want to register 2 or more repeaters to the base unit, contact an authorised service centre.

Setting the repeater mode

1 [☰] [#] 1 3 8

2 [↕]: Select the desired setting. → [OK]
→ [☎]

Registering the DECT repeater (KX-A405/KX-A406) to the base unit

Note:

- Please use a repeater that has not yet been registered to another unit. If the repeater is registered to another unit, deregister it first, referring to the Installation Guide for the DECT repeater.

1 Base unit:

Press and hold [●] for about 5 seconds.

2 DECT repeater:

Connect the AC adaptor, then wait until the ① indicator and ∇ indicator light green.

3 Base unit:

To exit the registration mode, press [●].

Caller ID Service

Using Caller ID service

Important:

- This unit is Caller ID compatible. To use Caller ID features, you must subscribe to a Caller ID service. Contact your phone service provider for details.

Caller ID features

When an outside call is being received, the caller information is displayed.

Caller information for the last 50 callers is logged in the caller list from the most recent call to the oldest.

- If the unit cannot receive caller information, the following is displayed:
 - “**Out of Area**”: The caller dials from an area which does not provide a Caller ID service.
 - “**Private Caller**”: The caller requests not to send caller information.
- If the unit is connected to a PBX system, caller information may not be properly received. Contact your PBX supplier.

Talking Caller ID

This feature lets you know who is calling by announcing the caller's phone number.

To use this feature, you must:

- subscribe to a Caller ID service of your phone service provider.
- turn this feature on (page 22).

When caller information is received, the handset announces the caller's phone number received from your phone service provider following every ring.

Caller list

Viewing the caller list and calling back

- 1 [→]

- 2 Press [▼] to search from the most recent call, or press [▲] to search from the oldest call.
- 3 To call back, press [↶].

Editing a caller's phone number

- 1 [→]
- 2 [↕]: Select the desired entry. → [⏏]
- 3 [↕]: “Edit & Call” → [OK]
- 4 Edit the number.
- 5 [↶]

Erasing selected caller information

- 1 [→]
- 2 [↕]: Select the desired entry.
- 3 [X] → [↕]: “Yes” → [OK] → [🔇]

Voicemail service

Voicemail is an answering service that may be offered by your phone service provider. This service can also record calls when you are unavailable to answer the phone or when your line is busy. Messages are recorded on the phone company system.

When you have new messages,  is displayed on the handset if message indication service is available. Please contact your phone service provider for details of this service.

Important:

- If  still remains on the display even after you have listened to new messages, turn it off by pressing and holding **[END]** for 2 seconds.

Character entry

The dial keys are used to enter characters and numbers. Each dial key has multiple characters assigned to it. The characters that can be entered depend on the character entry mode (page 31).

- Press **[←]** or **[→]** to move the cursor left or right.
- Press dial keys to enter characters and numbers.
- Press **[C]** to erase the character or number highlighted by the cursor. Press and hold **[C]** to erase all characters or numbers.
- Press **[A→a]** to switch between uppercase and lowercase.
- To enter another character located on the same dial key, press **[→]** to move the cursor to the next space, then press the appropriate dial key.
- If you do not press any dial key within 2 seconds after entering a character, the character is fixed and the cursor moves to the next space.

Character entry modes

When the unit displays the character entry screen:
[R/ECO] → [↑]: Select a character entry mode. → **[OK]**

Note:

- $_$ in the following tables represents a single space.

Alphabet character table (ABC)

0	1	2	3	4	5	6	7	8	9	#
$_$ 0	& ' ()	A B C	D E F	G H I	J K L	M N O	P Q R	T U V	W X Y	#
	* , - .	2	3	4	5	6	S 7	8	Z 9	
	/ 1	a b c	d e f	g h i	j k l	m n o	p q r s	t u v	w x y	
		2	3	4	5	6	7	8	z 9	

Numeric entry table (0-9)

0	1	2	3	4	5	6	7	8	9	#
0	1	2	3	4	5	6	7	8	9	#

Useful Information

Greek character table (ΑΒΓ)

0	1	2	3	4	5	6	7	8	9	#
~ 0	& ' () * , - . / 1	Α Β Γ 2	Δ Ε Ζ 3	Η Θ Ι 4	Κ Λ Μ 5	Ν Ξ Ο 6	Π Ρ Σ 7	Τ Υ Φ 8	Χ Ψ Ω 9	#

Extended 1 character table (ΑĂĂ)

0	1	2	3	4	5	6	7	8	9	#
~ 0	& ' () * , - . / 1	Α Ă Ā Ă Ă Ă Ă Æ Β Ç Ć 2	Δ Ε Ę É Ê Ě Ë Ě 3	Γ Ğ Η Ī Ĭ Ĩ Ĵ Ķ Ĺ 4	Κ Λ 5	Μ Ν Ń Ō Ő Ó Ŏ Ő Ő 6	Π Ρ Σ Ş Ş β 7	Τ Ů Ű Ú Ū Ŷ Û Ŵ 8	Χ Ψ Ξ Υ ŷ Ζ 9	#
		a à á â ã ä å æ b ç ĉ 2	d e è é ê ë ë ě 3	g ğ h ĭ ĩ ĵ ĵ ħ 4	j k l 5	m n ñ o ò ó ô õ ö 6	p q r s ş ş β 7	t u ù ú û ů ü v 8	w ŵ x y ŷ z 9	

- The following are used for both uppercase and lowercase: ø Ŵ ŷ

Extended 2 character table (ŠŚŠ)

0	1	2	3	4	5	6	7	8	9	#
~ 0	& ' () * , - . / 1	Α Ă Ā Ą Β Ć Ĉ Ć 2	Δ Ď Ę É Ě Ě Ë Ě 3	Γ Ğ Η Ī Ĭ Ĩ Ĵ Ķ Ĺ 4	Κ Λ 5	Μ Ν Ń Ō Ő Ó Ŏ Ő Ő 6	Π Ρ Σ Ř Ŕ Ŗ Ś Ś 7	Τ Ů Ű Ú Ū Ŷ Û Ŵ 8	Χ Ψ Ξ Ÿ Ź Ž Ž Ž 9	#
		a á ā Ą b c Ĉ Ć 2	d ě e é ě ě ë ě 3	g ğ h ĩ ĵ ħ 4	j k l ĺ Ĺ ĺ 5	m n ñ ň o ó ô õ ö 6	p q r Ř ŕ s Ś ś 7	t Ů Ű ú ū ů ü v 8	w x y ŷ Ź Ž Ž Ž 9	

- The following are used for both uppercase and lowercase:

Ą Ć Ĉ Ě ĺ Ĺ ĺ Ŕ Ŗ Ś ś ů ŷ Ž Ž Ž

Cyrillic character table (АБВ)

0	1	2	3	4	5	6	7	8	9	#
~ 0 Г Є І І Ÿ	& ' () * , - . / 1	А Б В Г 2	Д Е Ж З 3	И Й К Л 4	М Н О П 5	Р С Т У 6	Ф Х Ц Ч 7	Ш Щ Ъ Ы 8	Ь Э Ю Я 9	#

Error messages

Display message	Cause/solution
Base no power or No link. Reconnect AC adaptor. or No link.	<ul style="list-style-type: none"> ● Confirm the base unit's AC adaptor is connected to the unit and the power outlet correctly. ● The handset has lost communication with the base unit. Move closer to the base unit and try again. ● Unplug the base unit's AC adaptor to reset the unit. Reconnect the adaptor and try again. ● The handset's registration may have been cancelled. Re-register the handset (page 28). ● When "No link." is displayed during a power failure, place a handset on the base unit to supply power to the base unit.
Check Phone Line	<ul style="list-style-type: none"> ● The supplied telephone line cord has not been connected yet or not connected properly. Check the connections (page 8).
Memory Full	<ul style="list-style-type: none"> ● The phonebook memory is full. Erase unwanted entries (page 19). ● The call block list memory is full. Erase unwanted entries (page 18). ● The maximum number of base units (4) is already registered to the handset. Cancel unused base unit registrations from the handset (page 29).
Use rechargeable battery.	<ul style="list-style-type: none"> ● A wrong type of battery such as alkaline or manganese was inserted. Use only the rechargeable Ni-MH batteries noted on page 3, 6.

Troubleshooting

If you still have difficulties after following the instructions in this section, disconnect the base unit's AC adaptor and turn off the handset, then reconnect the base unit's AC adaptor and turn on the handset.

General use

Problem	Cause/solution
The handset does not turn on even after installing charged batteries.	<ul style="list-style-type: none"> ● Place the handset on the base unit or charger to turn on the handset.

Useful Information

Problem	Cause/solution
The unit does not work.	<ul style="list-style-type: none">● Make sure the batteries are installed correctly (page 8).● Fully charge the batteries (page 9).● Check the connections (page 8).● Unplug the base unit's AC adaptor to reset the unit and turn off the handset. Reconnect the adaptor, turn on the handset and try again.● The handset has not been registered to the base unit. Register the handset (28).
The handset display is blank.	<ul style="list-style-type: none">● The handset is not turned on. Turn the power on (page 11).
I cannot hear a dial tone.	<ul style="list-style-type: none">● Make sure that you are using the supplied telephone line cord. Your old telephone line cord may have a different wiring configuration.● The base unit's AC adaptor or telephone line cord is not connected. Check the connections.
I cannot use the intercom feature.	<ul style="list-style-type: none">● This feature is available between the handsets. Although the handset displays "Intercom", or "Auto Intercom", these features are not available for single handset models.
Time on the unit has shifted.	<ul style="list-style-type: none">● Incorrect time information from incoming Caller ID changes the time. Set the time adjustment to "Manual" (off) (page 22).

Menu list

Problem	Cause/solution
I cannot activate the eco mode.	<ul style="list-style-type: none">● You cannot set eco mode when you set the repeater mode "on". If required, set the repeater mode to "off" (page 29).
I cannot remember the key lock password.	<ul style="list-style-type: none">● If you forget your password, contact an authorised service centre.

Battery recharge

Problem	Cause/solution
I fully charged the batteries, but <ul style="list-style-type: none">–  still flashes or– the operating time seems to be shorter.	<ul style="list-style-type: none">● Clean the battery ends (+, -) and the charge contacts with a dry cloth and charge again.● It is time to replace the batteries (page 8).

Useful Information

Making/answering calls, intercom

Problem	Cause/solution
📞 is displayed.	<ul style="list-style-type: none">• The handset is too far from the base unit. Move closer.• The base unit's AC adaptor is not properly connected. Reconnect AC adaptor to the base unit.• The handset is not registered to the base unit. Register it (page 28).• Activating eco mode reduces the range of the base unit in standby mode. If required, turn eco mode off (page 12).
Noise is heard, sound cuts in and out.	<ul style="list-style-type: none">• You are using the handset or base unit in an area with high electrical interference. Re-position the base unit and use the handset away from sources of interference.• Move closer to the base unit.• If you use a DSL/ADSL service, we recommend connecting a DSL/ADSL filter between the base unit and the telephone line jack. Contact your DSL/ADSL provider for details.
Sound quality seems to be getting worse.	<ul style="list-style-type: none">• You have registered a handset that is not recommended. The clearest sound quality is only possible by registering the provided handset.
The handset does not ring.	<ul style="list-style-type: none">• The ringer volume is turned off. Adjust ringer volume (page 13, 22).• Do not disturb mode is turned on. Turn it off (page 25).• If the handset is registered to multiple base units, the handset may not be able to make or receive calls or communicate with the base unit when the following conditions are met.<ul style="list-style-type: none">– Base unit selection is set to "Auto" (page 23). In this case, place the handset near the base unit, then press [R/ECO] and select "ECO" or "ECO OFF". Repeat for each base unit.
I cannot make a call.	<ul style="list-style-type: none">• The dialling mode may be set incorrectly. Change the setting (page 12).• You dialled a call restricted number (page 28).• The key lock feature is turned on. Turn it off (page 15).

Caller ID/Talking Caller ID

Problem	Cause/solution
Caller information is not displayed.	<ul style="list-style-type: none">• You must subscribe to a Caller ID service. Contact your phone service provider for details.• If your unit is connected to any additional telephone equipment, remove and plug the unit directly into the wall jack.• If you use a DSL/ADSL service, we recommend connecting a DSL/ADSL filter between the base unit and the telephone line jack. Contact your DSL/ADSL provider for details.
Caller information is displayed or announced late.	<ul style="list-style-type: none">• Depending on your phone service provider, the unit may display or announce the caller's information at the 2nd ring or later. Set the first ring to "OFF" (page 22).

Useful Information

Problem	Cause/solution
Caller's phone number is not announced.	<ul style="list-style-type: none">• The handset's ringer volume is turned off. Adjust it (page 13, 22).• The Talking Caller ID feature is turned off. Turn it on (page 22).
The name stored in the phonebook is not fully displayed while an outside call is being received.	<ul style="list-style-type: none">• Edit the phonebook entry name to fit in 1 line of text (page 19).

Liquid damage

Problem	Cause/solution
Liquid or other form of moisture has entered the handset/base unit.	<ul style="list-style-type: none">• Disconnect the AC adaptor and telephone line cord from the base unit. Remove the batteries from the handset and leave to dry for at least 3 days. After the handset/base unit are completely dry, reconnect the AC adaptor and telephone line cord. Insert the batteries and charge fully before use. If the unit does not work properly, contact an authorised service centre.

Caution:

- To avoid permanent damage, do not use a microwave oven to speed up the drying process.

Index

- A** Additional base units: 28
Alarm: 25
Answering calls: 13
Auto intercom: 15
Auto talk: 13, 23
- B** Baby monitor: 26
Base unit
 Cancelling: 29
 Selecting: 29
Battery: 8
- C** Call restriction: 28
Call share: 14
Call waiting: 13
Call Waiting Caller ID: 13
Caller ID service: 30
Caller list: 30
Caller list edit: 30
Category: 19
Chain dial: 19
Character entry: 31
Conference calls: 14
- D** Date and time: 12
Dialling mode: 12
Direct command code: 21
Display
 Contrast: 23
 Language: 11
Do not disturb mode: 25
- E** Eco mode: 12
Equalizer: 14
Error messages: 33
- F** First ring: 22
- H** Handset
 Deregistration: 29
 Name: 27
 Registration: 28
Hold: 13
- I** Intercom: 15
- K** Key lock: 15
Keytones: 23
- L** Low battery alert: 12
- M** Making calls: 13
Mute: 13
- N** Noise reduction: 14
Nuisance Call block: 17
- P** Pause: 13
Phonebook: 19
PIN: 28
Power failure (power backup operation): 16
Power on/off: 11
Privacy mode: 23
- R** Recall/flash: 13
Redialling: 13
Repeater: 29
Ringer tone: 22
- S** Security for phone calls: 28
Speakerphone: 13
Speed dial: 20
- T** Talking Caller ID: 30
Temporary tone dialling: 14
Time adjustment: 22
Transferring calls: 14
Troubleshooting: 33
- V** Voicemail: 31
Volume
 Receiver: 13
 Ringer (Handset): 13, 22
 Speaker: 13

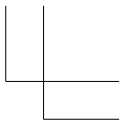
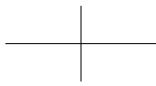
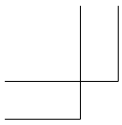

Notes

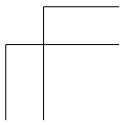
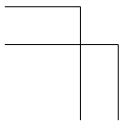
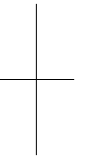
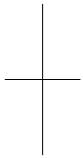

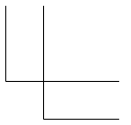
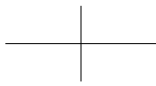
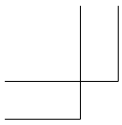

Notes

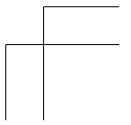
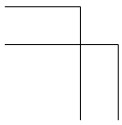
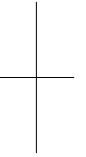
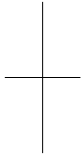

For your future reference

We recommend keeping your warranty card and a record of the following information to assist with any repair under warranty.

Serial No.	Date of purchase
(found on the bottom of the base unit)	
Name and address of dealer	

Attach your purchase receipt here.

Hotline Tel. No.: 2313 0666

Sole Agent for Hong Kong & Macau:

Shun Hing Technology Co., Ltd.

Block B, 9/F., Peninsula Centre 67 Mody Road Tsimshatsui East Kowloon,

Hong Kong

Tel: 2313 0888

Hotline: 2313 0666

Fax: 2368 8068

Email address: shtec@panasonic.oa.hk

Panasonic Corporation

1006, Oaza Kadoma, Kadoma-shi, Osaka 571-8501, Japan

<http://www.panasonic.com>

© Panasonic Corporation 2019

PNQX8888ZA
PNQX8888ZA

PNQX8888ZA PP0819BQ0